

Cybersecurity Likes Collaboration: DNS Abuse

2023.09.23 | YIGF Cambodia

Important Note: This document was prepared for a private audience. Copyrights for images included in the presentation have not been obtained from the right owners. If you are a right owner and wish for the images not to continue to be included, please contact us via email: info@dot.asia

www.asia
Asian #InspirAsian



.asia
#RiseWithAsia

What is “.asia”?

www.domain.asia

Every .Asia Domain Contributes to Internet Development in Asia



Youth engagement program on Internet Governance & Digital Inclusion. Ambassadors selected from Universities are trained on global Internet issues and tasked with implementing their own projects. Alumni projects have touched Primary & Secondary School Students and Beyond.





TYPES OF ATTACK

Remote/Offsite Attacks

Physical/Onsite Attack

TYPES OF ATTACK

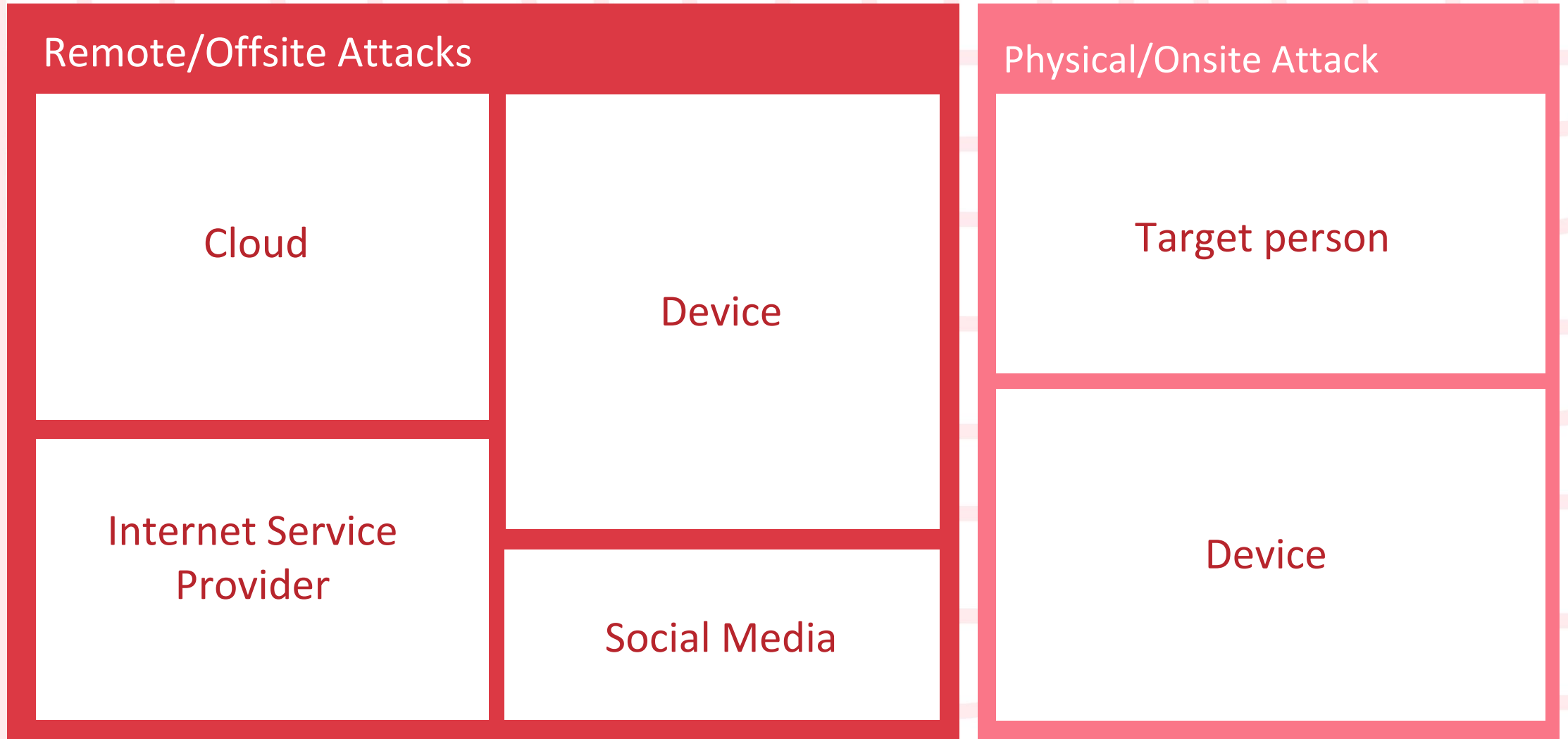

TYPES OF ATTACK (EXAMPLES)

Remote/Offsite Attacks

Cloud

- ◆ Compromised login and password
- ◆ Service provider being hacked
- ◆ Intercepted email and sms confirmations

Internet Service Provider

- ◆ Data in transit
- ◆ Information requests by authorities

Device

- ◆ Phishing website / email / message
- ◆ Unknown software & Malware

Social Media

- ◆ Privacy compromised

Physical/Onsite Attack

Target person

- ◆ Surveillance
- ◆ Trailing
- ◆ Eavesdropping

Device

- ◆ Breaking into device
- ◆ Brute force password break in

CYBERSECURITY APPROACH & ATTITUDE

- No system is 100% secure
 - Human factors (leakage by and compromise of personnel)
- No single solution
- Increase the cost of attack
 - Understand risk profile
 - Prioritization
 - Cost-benefit considerations (Cost of attack)
- Emphasis on resilience
 - Ability to return system to service after compromise/attack
 - Distribute risk



BRUTE FORCE CRACKING OF PASSWORD

	Lowercase letters only	At least one uppercase letter	At least one uppercase letter +number	At least one uppercase letter +number+symbol
1	Instantly	Instantly	-	-
2	Instantly	Instantly	Instantly	-
3	Instantly	Instantly	Instantly	Instantly
4	Instantly	Instantly	Instantly	Instantly
5	Instantly	Instantly	Instantly	Instantly
6	Instantly	Instantly	Instantly	Instantly
7	Instantly	Instantly	1 min	6 min
8	Instantly	22 min	1 hrs	8 hrs
9	2 min	19 hrs	3 days	3 wks
10	1 hrs	1 mths	7 mths	5 yrs
11	1 day	5 yrs	41 yrs	400 yrs
12	3 wks	300 yrs	2,000 yrs	34,000 yrs

Source: Security.org



PASSWORD TIPS



Y o u a r e s a f e i n m y h e a r t a n d
M y h e a r t w i l l g o o n a n d o n



YasimhaMhwgoao8..(

number signs

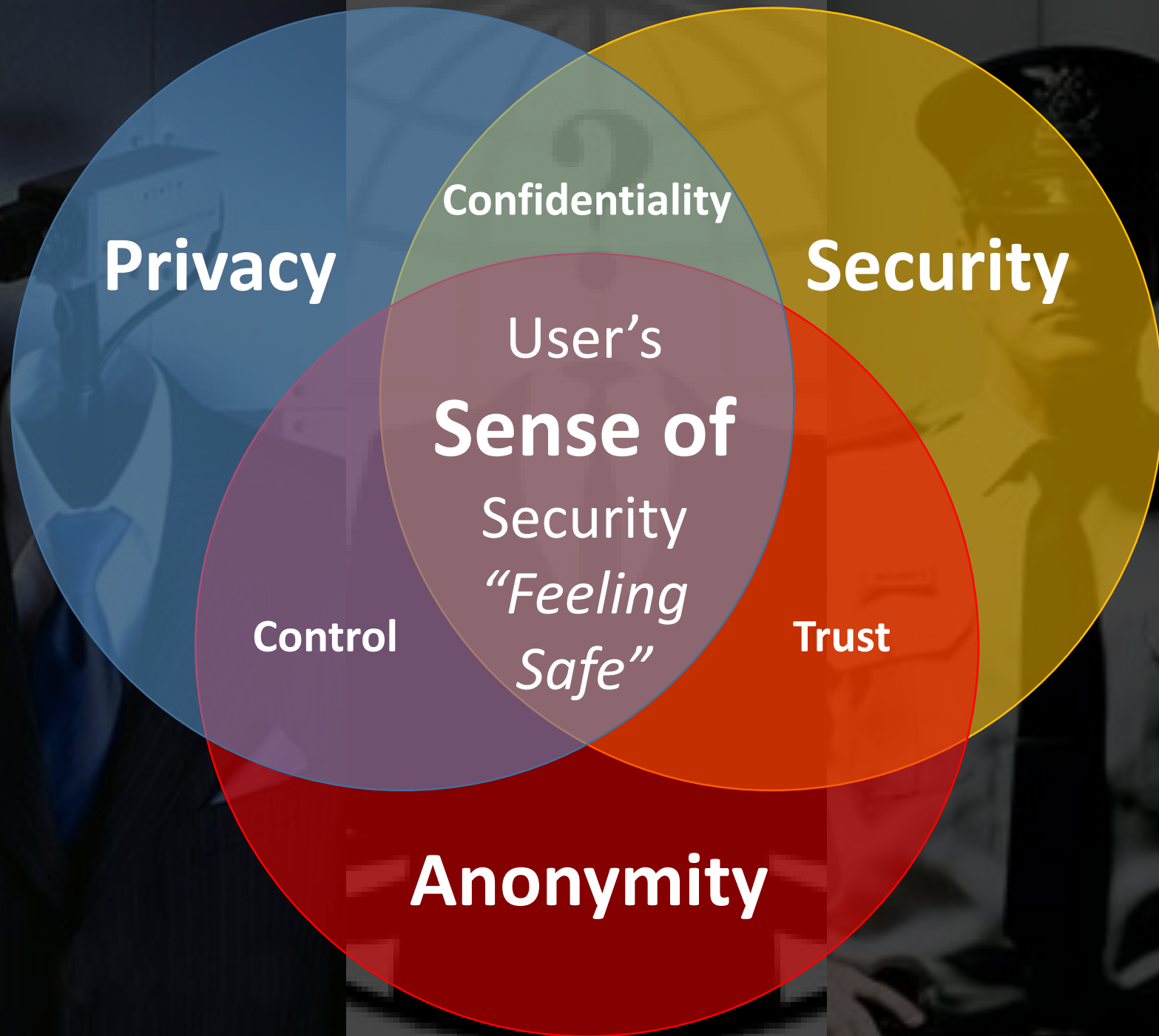

Privacy

Confidentiality

Security

**User's
Sense of
Security
"Feeling
Safe"**

Control

Trust

Anonymity

LIBERTY

JUSTICE

SECURITY

GLUE

Freedom

For



Privately Owned Public Spaces (POPS)





MacBook Air







Informed Consent

January 2017

PERSONAL

DIGITAL

SOVEREIGNTY

DEBUNKING SECURITY BY OBSCURITY

False sense of security







Social / Cultural / Economics

Legal / Jurisdictional

Content

Technical

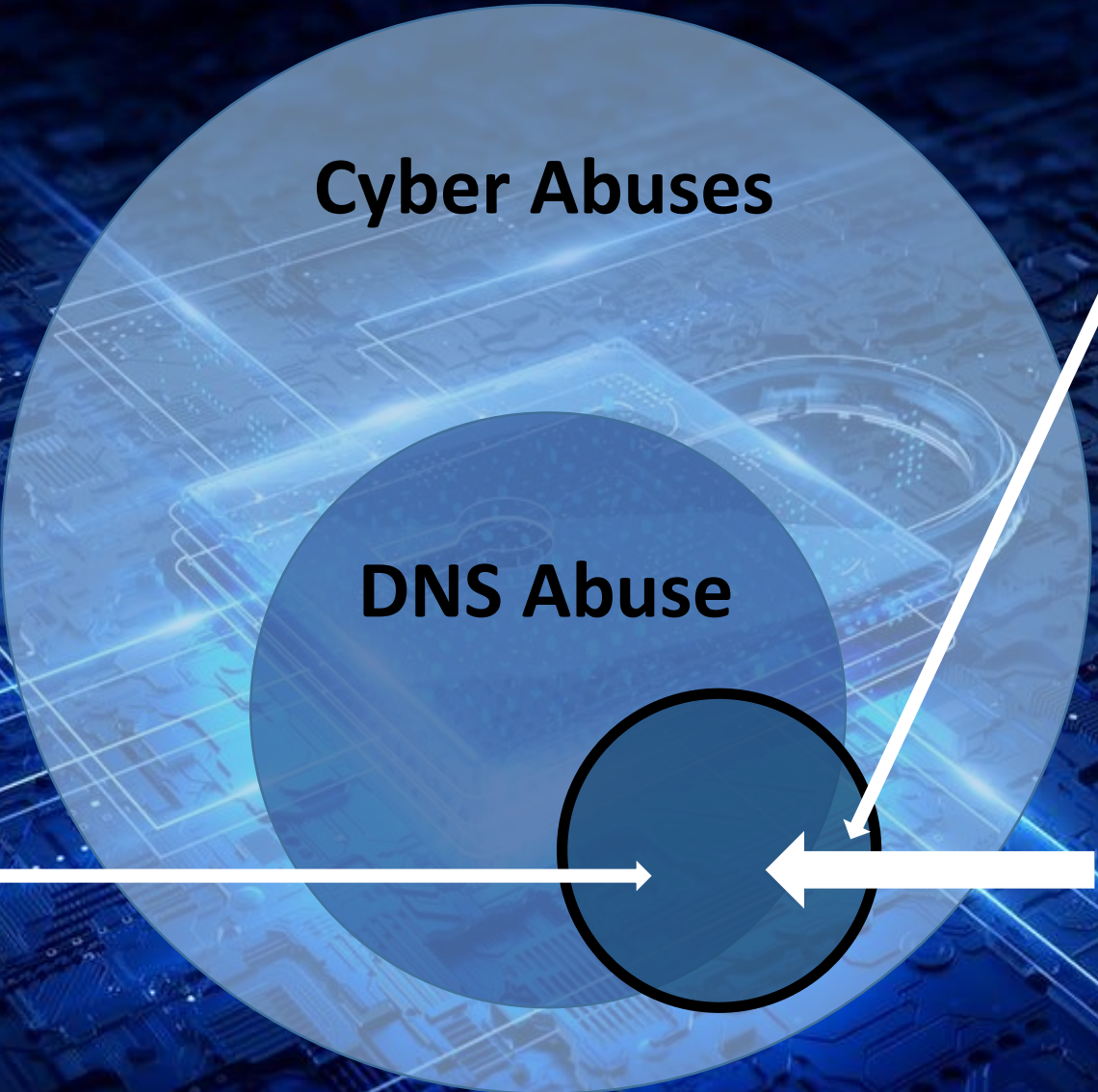

Cyber Abuses

DNS Abuse

DNS Abuses that TLD registries are to mitigate against (Phishing, malware, etc.)

Not DNS Abuses that TLD registries do have policies and processes to mitigate against (e.g. UDRP & Rights Protection, CSAM, etc.)

Abuses appropriate for mitigation by Top Level Domain (TLD) Registries

DNS Abuse "Ecosystem"

(gTLDs)

Within ICANN Remit

Beyond ICANN

Abuse

DNS

Infrastructure

Content

End Users

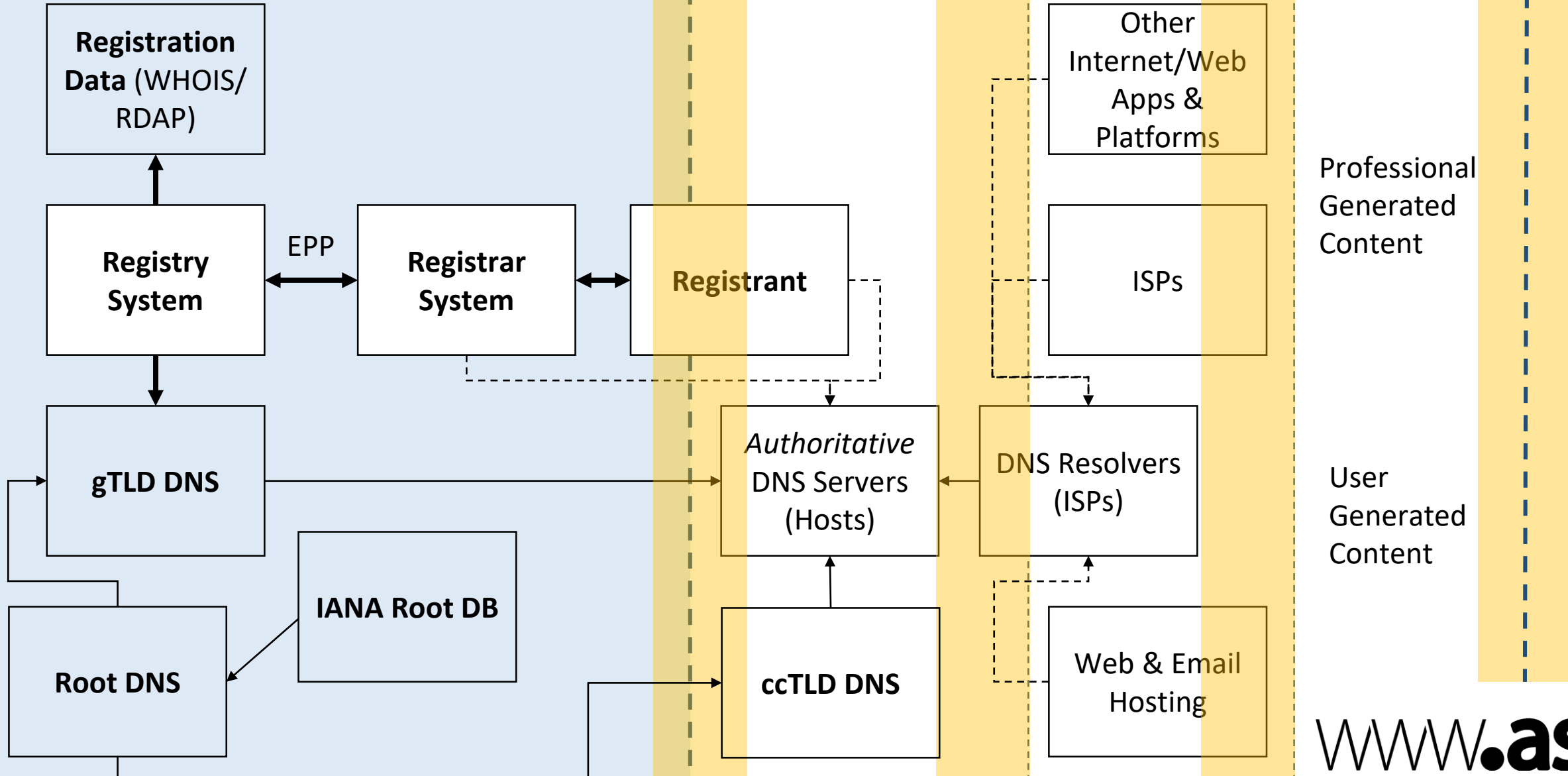



Kenny Huang

Managing Director and CEO, TWNIC

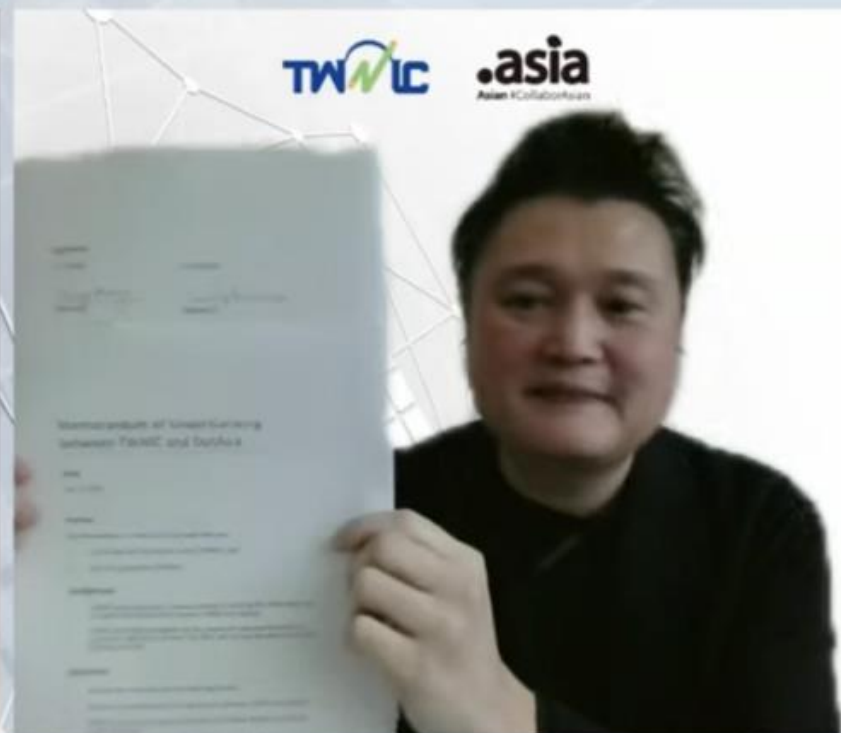

Edmon Chung

CEO, DotAsia Organisation



Jia-Rong Low

VP, Stakeholder Engagement
and Managing Director - Asia Pacific, ICANN





Global Public Interest

- 16330,750

- 15942,51535,65

- 6715,80

3,713 %

+

2,766 %

- 29748,09

4,801 %

4,141 %

1,626 %

31462,04

- 10653,67

1,568 %

- 655

1,760 %

- 27135,17

10272,69

+

- 16330,750

- 15942,51535,65

- 6715,80

- 8488,74

- 17786,46

2,327 %

- 25257,23

1,11 %

- 3649,89

5,246,53 %

31674

24158,26

+

3,686 %

4,833 %



Multistakeholder Model

The Internet of Trust

INTERNET GOVERNANCE FORUM
PARIS, 12-14 NOVEMBER 2018



Help keep .KiDS safe

[Submit Abuse Report](#)

THE FOLLOWING **PREVIEW** HAS BEEN APPROVED FOR
RESTRICTED AUDIENCES ONLY
BY THE MOTION PICTURE ASSOCIATION OF AMERICA, INC.

THE FILM ADVERTISED HAS BEEN RATED

R	RESTRICTED 
	UNDER 17 REQUIRES ACCOMPANYING PARENT OR ADULT GUARDIAN [®]
PERVERSIVE VIOLENCE, DRINKING, LANGUAGE, BLOOD AND GORE, SOME THEMATIC ELEMENTS, STYLIZED ACTION SEQUENCES AND A SCENE OF RAPE	

www.filmratings.com

www.mpaa.org

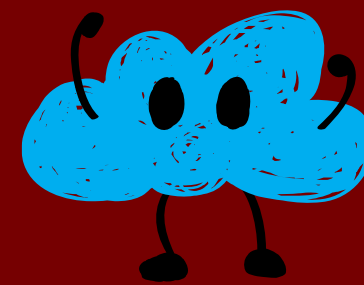

The future depends on what you do today.
MAHATMA GANDHI



The Internet lives where anyone can access it.
VINT CERF
Father of the Internet



Cybersecurity Likes Collaboration
Multistakeholder approach is critical

Cybersecurity is Built on Openness
Open Source, Open Standards & End-to-end Encryption

Cybersecurity is For Everyone
Understanding Risk Profile & Increasing Cost of Attack





Thank You

edmon@dot.asia



www.asia

Asian #GenerAsian